



LDH1 system

PRODUCT CATALOGUE

Germany

Johannes Lübbering GmbH
Industriestraße 4
33442 Herzebrock-Clarholz

Telephone: +49 (52 45) 83 09-0
Fax: +49 (52 45) 83 09-250
info@luebbering.de
www.luebbering.de

United Kingdom

Luebbering (UK) Ltd.
418 Oakshott Place
Walton Summit Industrial Estate
Bamber Bridge
Preston
Lancashire
PR5 8AT

Telephone: +44 (1772) 312288
Fax: +44 (19 25) 751-752
info@luebbering.co.uk
www.luebbering.co.uk

China

Lübbering Tools Trading (Shanghai) Co., Ltd.
www.luebbering.com

USA

Luebbering Corp.
www.luebbering.com

TABLE OF CONTENTS

1.	GENERAL INFORMATION	4
1.1	Overview	5
1.2	Collet chucks	6
1.3	Drilling tools	6
2.	DESOUTTER INTERFACE	7
2.1	Tools	7
2.2	L.DH1 system 03-XX-XX – straight	8
2.3	L.DH1 system 04-XX-XX – straight	9
2.4	L.DH1 system 06-XX-XX – straight	10
2.5	L.DH1 system 08-XX-XX – straight	11
2.6	L.DH1 system 06-XX-XX – right-angled	12
2.7	L.DH1 system 06-XX-XX – left-angled	13
3.	ATLAS COPCO INTERFACE	14
3.1	Tools	14
3.2	L.DH1 system 03-XX-XX – straight	15
3.3	L.DH1 system 04-XX-XX – straight	16
3.4	L.DH1 system 06-XX-XX – straight	17
3.5	L.DH1 system 08-XX-XX – straight	18
3.6	L.DH1 system 06-XX-XX – right-angled	19
3.7	L.DH1 system 06-XX-XX – left-angled	20

1. GENERAL INFORMATION

L.DH1 system drilling systems are available in wide range of designs to match your specific application.

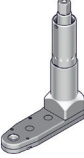
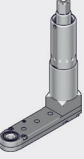
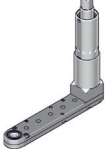
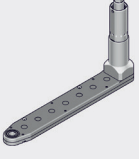
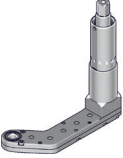
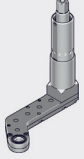
L.DH1 SYSTEM		ALIGNMENT
03-XX-XX		straight
04-XX-XX		
06-XX-XX		
08-XX-XX		
06-XX-XX		right-angled
06-XX-XX		left-angled

These can be used in combination with commercially available tools from Atlas Copco and Desoutter thanks to the various different adapter interfaces for L.DH1.

Depending on requirements, we offer thread sockets and collet chuck sockets in various sizes.

Drilling tools with a diameter of up to 8 mm can be used. The L.DH1 drilling offset head is designed for the most demanding requirements and for the speeds achieved by commercially available tools.

1.1 OVERVIEW

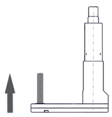
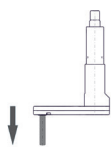
SOCKET FOR DRILLING TOOL / COLLET CHUCK		DRILLING SYSTEM		TOOL	FURTHER INFORMATION	
SIZE	INSTALLATION DIRECTION	L.DH1 SYSTEM	ALIGNMENT	INTERFACE		
<p>THREAD 1/4-28 UNF-2B FOR DRILLING TOOLS</p> <p>THREAD 9/32-40 UNS FOR COLLET CHUCKS</p>	top 	03-XX-XX	straight	Desoutter	Further information on page 8	
				Atlas Copco	Further information on page 15	
				06-XX-XX	Desoutter	Further information on page 9
					Atlas Copco	Further information on page 16
				06-XX-XX	Desoutter	Further information on page 10
					Atlas Copco	Further information on page 17
	bottom 	08-XX-XX		Desoutter	Further information on page 11	
				Atlas Copco	Further information on page 18	
			06-XX-XX	right-angled	Desoutter	Further information on page 12
				Atlas Copco	Further information on page 19	
			06-XX-XX	left-angled	Desoutter	Further information on page 13
				Atlas Copco	Further information on page 20	

1.2 COLLET CHUCKS

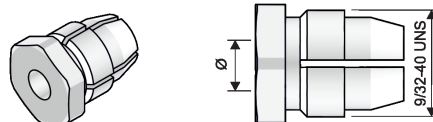

SOCKET Ø [mm]	ITEM NO.	SOCKET Ø [mm]	ITEM NO.	SOCKET Ø [mm]	ITEM NO.	SOCKET Ø [mm]	ITEM NO.	SOCKET Ø [mm]	ITEM NO.
1,0	37200001	1,9	37200010	2,8	37200019	3,7	37200028	4,6	37200037
1,1	37200002	2,0	37200011	2,9	37200020	3,8	37200029	4,7	37200038
1,2	37200003	2,1	37200012	3,0	37200021	3,9	37200030	4,8 (3/16")	37200039
1,3	37200004	2,2	37200013	3,1	37200022	4,0 (5/32")	37200031	4,9	37200040
1,4	37200005	2,3	37200014	3,2	37200023	4,1	37200032	5,0	37200041
1,5	37200006	2,4 (3/32")	37200015	3,3	37200024	4,2	37200033		
1,6 (1/16")	37200007	2,5	37200016	3,4	37200025	4,3	37200034		
1,7	37200008	2,6	37200017	3,5	37200026	4,4	37200035		
1,8	37200009	2,7	37200018	3,6	37200027	4,5	37200036		

1.3 DRILLING TOOLS

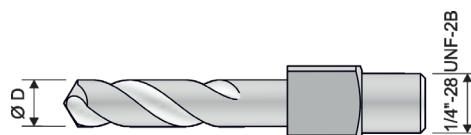

Ø D [mm]	ITEM NO.	Ø D [mm]	ITEM NO.	Ø D [mm]	ITEM NO.	Ø D [mm]	ITEM NO.	Ø D [mm]	ITEM NO.
1,78	37300050	2,49	37300040	3,27	37300030	4,09	37300020	4,92	37300010
1,85	37300049	2,53	37300039	3,45	37300029	4,22	37300019	4,98	37300009
1,93	37300048	2,58	37300038	3,57	37300028	4,30	37300018	5,06	37300008
1,99	37300047	2,64	37300037	3,66	37300027	4,39	37300017	5,11	37300007
2,06	37300046	2,71	37300036	3,73	37300026	4,50	37300016	5,18	37300006
2,08	37300045	2,79	37300035	3,80	37300025	4,57	37300015	5,22	37300005
2,18	37300044	2,82	37300034	3,86	37300024	4,62	37300014	5,31	37300004
2,26	37300043	2,87	37300033	3,91	37300023	4,70	37300013	5,41	37300003
2,37	37300042	2,95	37300032	3,99	37300022	4,80	37300012	5,61	37300002
2,44	37300041	3,05	37300031	4,04	37300021	4,85	37300011	5,79	37300001

2. DESOUTTER INTERFACE

2.1 TOOLS

TYPE	MODEL	MANUFACTURER NO.	ROTATIONAL SPEED [rpm]	OUTPUT [W]
MULTI-DRILL – PISTOL	DR350-P5500-QR	205 147 984 4	5500	350
	DR350-P4500-QR	205 147 983 4	4500	350
	DR350-P3000-QR	205 147 528 4	3000	350
	DR350-P1000-QR	205 147 981 4	1000	350
	DR500-P5800-QR	615 176 190 0	5800	500
	DR500-P4300-QR	615 176 189 0	4300	500
	DR500-P2700-QR	615 176 188 0	2700	500
	DR500-P1800-QR	615 176 187 0	1800	500
	DR500-P1400-QR	615 176 186 0	1400	500
	DR500-P1000-QR	615 176 185 0	1000	500
MULTI-DRILL – STRAIGHT	DR300-T5500-QR	615 176 071 0	5500	300
	DR300-T4500-QR	615 176 070 0	4500	300
	DR300-T3000-QR	615 176 069 0	3000	300
	DR300-T2000-QR	615 176 068 0	2000	300
	DR300-T1000-QR	615 176 067 0	1000	300
	DR300-T1000-QR BRB	615 176 118 0	1000	300
	DR300-T550-QR	615 176 066 0	550	300
	DR450-T5800-QR	615 176 162 0	5800	450
	DR450-T4300-QR	615 176 161 0	4300	450
	DR450-T2700-QR	615 176 160 0	2700	450
	DR450-T1800-QR	615 176 159 0	1800	450
	DR450-T1400-QR	615 176 158 0	1400	450
	DR450-T1000-QR	615 176 157 0	1000	450



2.2 L.DH1 SYSTEM 03-XX-XX – STRAIGHT

Interface to drilling tool / collet chuck „X“

FOR DRILLING TOOL	FOR COLLET CHUCK	INSTALLATION DIRECTION
Thread 1/4-28 UNF-2B	Thread 9/32-40 UNS	top

Interface with the tool „Y“

MANUFACTURER	TYPE
Desoutter	Chapter 2.1 'Tools' on page 7

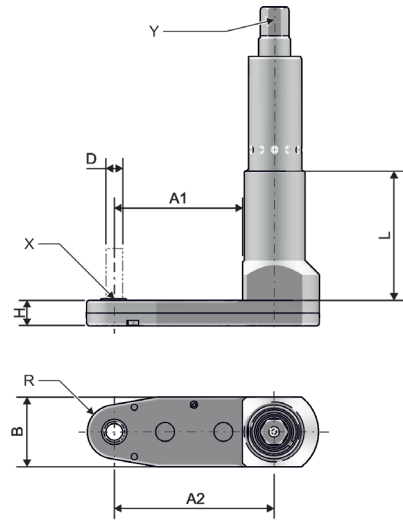

ITEM NO.	TYPE	MAX. Ø D [mm]	X	H [mm]	A1 [mm]	A2 [mm]	B [mm]	R [mm]	L [mm]	WEIGHT [kg]
99230801	03-08-48,5	5,0	1/4-28 UNF-2B	8,0	40,4	50,4	24,0	8,5	40,5	0,222
99230802	03-08-128	5,0	1/4-28 UNF-2B	8,0	40,4	50,4	24,0	8,5	120,0	0,347
99231001	03-10-50,5	6,35	1/4-28 UNF-2B	10,0	40,4	50,4	24,0	8,5	40,5	0,240
99231004	03-10-130	6,35	1/4-28 UNF-2B	10,0	40,4	50,4	24,0	8,5	120,0	0,365
99231300	03-12,5-53	8,0	1/4-28 UNF-2B	12,5	40,4	50,4	24,0	8,5	40,5	0,267
99231301	03-12,5-132,5	8,0	1/4-28 UNF-2B	12,5	40,4	50,4	24,0	8,5	120,0	0,392
99230803	03-08-48,5	5,0	9/32-40 UNS	8,0	40,4	50,4	24,0	8,5	40,5	0,222
99230804	03-08-128	5,0	9/32-40 UNS	8,0	40,4	50,4	24,0	8,5	120	0,347
99231005	03-10-50,5	6,35	9/32-40 UNS	10,0	40,4	50,4	24,0	8,5	40,5	0,240
99231006	03-10-130	6,35	9/32-40 UNS	10,0	40,4	50,4	24,0	8,5	120,0	0,365
99231303	03-12,5-53	8,0	9/32-40 UNS	12,5	40,4	50,4	24,0	8,5	40,5	0,266
99231304	03-12,5-132,5	8,0	9/32-40 UNS	12,5	40,4	50,4	24,0	8,5	120,0	0,392



2.3 L.DH1 SYSTEM 04-XX-XX – STRAIGHT

Interface to drilling tool / collet chuck „X“

FOR DRILLING TOOL	FOR COLLET CHUCK	INSTALLATION DIRECTION
Thread 1/4-28 UNF-2B	Thread 9/32-40 UNS	bottom

Interface with the tool „Y“

MANUFACTURER	TYPE
Desoutter	Chapter 2.1 'Tools' on page 7

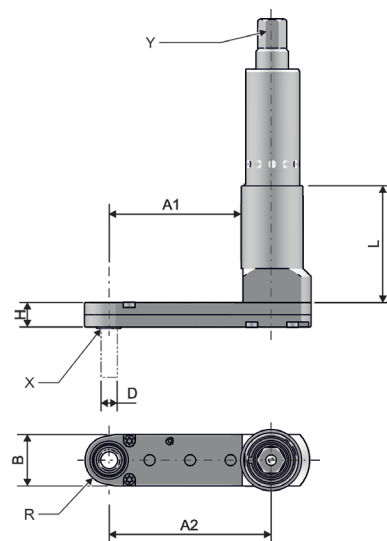

ITEM NO.	TYPE	MAX. Ø D [mm]	X	H [mm]	A1 [mm]	A2 [mm]	B [mm]	R [mm]	L [mm]	WEIGHT [kg]
99240802	04-7,5-43,5	5,0	1/4-28 UNF-2B	7,5	40,9	50,4	16,0	7,5	36,0	0,174
99240801	04-08-48,5	5,0	1/4-28 UNF-2B	8,0	58,8	68,8	24,0	8,5	40,5	0,248
99240803	04-08-128	5,0	1/4-28 UNF-2B	8,0	58,8	68,8	24,0	8,5	120,0	0,373
99241001	04-10-50,5	6,35	1/4-28 UNF-2B	10,0	58,8	68,8	24,0	8,5	40,5	0,272
99241002	04-10-130	6,35	1/4-28 UNF-2B	10,0	58,8	68,8	24,0	8,5	120,0	0,397
99241303	04-12,5-53	8,0	1/4-28 UNF-2B	12,5	58,8	68,8	24,0	8,5	40,5	0,304
99241302	04-12,5-132,5	8,0	1/4-28 UNF-2B	12,5	58,8	68,8	24,0	8,5	120,0	0,430
99240804	04-7,5-43,5	5,0	9/32-40 UNS	7,5	40,9	50,4	16,0	7,5	36,0	0,174
99240805	04-08-48,5	5,0	9/32-40 UNS	8,0	58,8	68,8	24,0	8,5	40,5	0,248
99240806	04-08-128	5,0	9/32-40 UNS	8,0	58,8	68,8	24,0	8,5	120,0	0,373
99241003	04-10-50,5	6,35	9/32-40 UNS	10,0	58,8	68,8	24,0	8,5	40,5	0,271
99241004	04-10-130	6,35	9/32-40 UNS	10,0	58,8	68,8	24,0	8,5	120,0	0,397
99241304	04-12,5-53	8,0	9/32-40 UNS	12,5	58,8	68,8	24,0	8,5	40,5	0,304
99241305	04-12,5-132,5	8,0	9/32-40 UNS	12,5	58,8	68,8	24,0	8,5	120,0	0,429



2.4 L.DH1 SYSTEM 06-XX-XX – STRAIGHT

Interface to drilling tool / collet chuck „X“

FOR DRILLING TOOL	FOR COLLET CHUCK	INSTALLATION DIRECTION
Thread 1/4-28 UNF-2B	Thread 9/32-40 UNS	bottom

Interface with the tool „Y“

MANUFACTURER	TYPE
Desoutter	Chapter 2.1 'Tools' on page 7

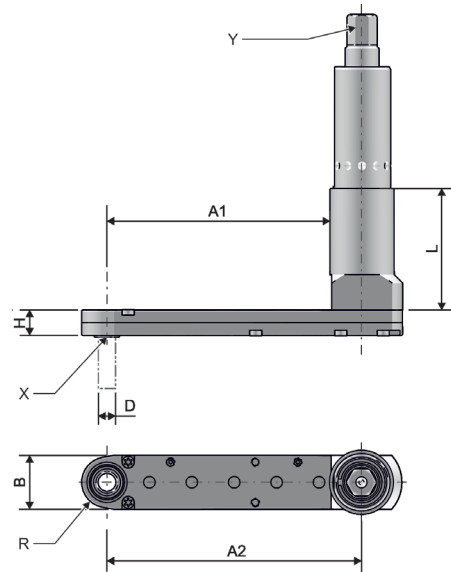

ITEM NO.	TYPE	MAX. Ø D [mm]	X	H [mm]	A1 [mm]	A2 [mm]	B [mm]	R [mm]	L [mm]	WEIGHT [kg]
99260802	06-7,5-43,5	5,0	1/4-28 UNF-2B	7,5	66,1	75,6	16,0	7,5	36,0	0,196
99260804	06-08-48,5	5,0	1/4-28 UNF-2B	8,0	95,6	105,6	24,0	8,5	40,5	0,300
99260805	06-08-128	5,0	1/4-28 UNF-2B	8,0	95,6	105,6	24,0	8,5	120,0	0,425
99261001	06-10-50,5	6,35	1/4-28 UNF-2B	10,0	95,6	105,6	24,0	8,5	40,5	0,334
99261002	06-10-130	6,35	1/4-28 UNF-2B	10,0	95,6	105,6	24,0	8,5	120,0	0,459
99261302	06-12,5-53	8,0	1/4-28 UNF-2B	12,5	95,6	105,6	24,0	8,5	40,5	0,380
99261303	06-12,5-132,5	8,0	1/4-28 UNF-2B	12,5	95,6	105,6	24,0	8,5	120,0	0,505
99260810	06-7,5-43,5	5,0	9/32-40 UNS	7,5	66,1	75,6	16,0	7,5	36,0	0,196
99260811	06-08-48,5	5,0	9/32-40 UNS	8,0	95,6	105,6	24,0	8,5	40,5	0,299
99260812	06-08-128	5,0	9/32-40 UNS	8,0	95,6	105,6	24,0	8,5	120,0	0,425
99261007	06-10-50,5	6,35	9/32-40 UNS	10,0	95,6	105,6	24,0	8,5	40,5	0,334
99261008	06-10-130	6,35	9/32-40 UNS	10,0	95,6	105,6	24,0	8,5	120,0	0,459
99261308	06-12,5-53	8,0	9/32-40 UNS	12,5	95,6	105,6	24,0	8,5	40,5	0,380
99261309	06-12,5-132,5	8,0	9/32-40 UNS	12,5	95,6	105,6	24,0	8,5	120,0	0,505



2.5 L.DH1 SYSTEM 08-XX-XX – STRAIGHT

Interface to drilling tool / collet chuck „X“

FOR DRILLING TOOL	FOR COLLET CHUCK	INSTALLATION DIRECTION
Thread 1/4-28 UNF-2B	Thread 9/32-40 UNS	bottom

Interface with the tool „Y“

MANUFACTURER	TYPE
Desoutter	Chapter 2.1 'Tools' on page 7

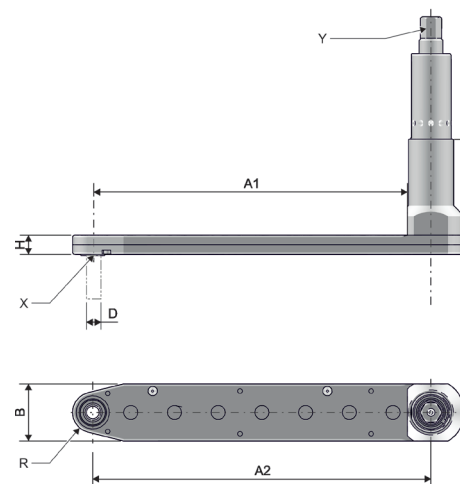

ITEM NO.	TYPE	MAX. Ø D [mm]	X	H [mm]	A1 [mm]	A2 [mm]	B [mm]	R [mm]	L [mm]	WEIGHT [kg]
99280800	08-7,5-43,5	5,0	1/4-28 UNF-2B	7,5	91,3	100,8	16,0	7,5	36,0	0,219
99280801	08-08-48,5	5,0	1/4-28 UNF-2B	8,0	132,4	142,4	24,0	8,5	40,5	0,352
99280802	08-08-128	5,0	1/4-28 UNF-2B	8,0	132,4	142,4	24,0	8,5	120,0	0,477
99281000	08-10-50,5	6,35	1/4-28 UNF-2B	10,0	132,4	142,4	24,0	8,5	40,5	0,397
99281001	08-10-130	6,35	1/4-28 UNF-2B	10,0	132,4	142,4	24,0	8,5	120,0	0,522
99281301	08-12,5-53	8,0	1/4-28 UNF-2B	12,5	132,4	142,4	24,0	8,5	40,5	0,457
99281302	08-12,5-132,5	8,0	1/4-28 UNF-2B	12,5	132,4	142,4	24,0	8,5	120,0	0,582
99280803	08-7,5-43,5	5,0	9/32-40 UNS	7,5	91,3	100,8	16,0	7,5	36,0	0,218
99280804	08-08-48,5	5,0	9/32-40 UNS	8,0	132,4	142,4	24,0	8,5	40,5	0,351
99280805	08-08-128	5,0	9/32-40 UNS	8,0	132,4	142,4	24,0	8,5	120,0	0,477
99281003	08-10-50,5	6,35	9/32-40 UNS	10,0	132,4	142,4	24,0	8,5	40,5	0,396
99281004	08-10-130	6,35	9/32-40 UNS	10,0	132,4	142,4	24,0	8,5	120,0	0,522
99281303	08-12,5-53	8,0	9/32-40 UNS	12,5	132,4	142,4	24,0	8,5	40,5	0,457
99281304	08-12,5-132,5	8,0	9/32-40 UNS	12,5	132,4	142,4	24,0	8,5	120,0	0,582



2.6 L.DH1 SYSTEM 06-XX-XX – RIGHT-ANGLED

Interface to drilling tool / collet chuck „X“

FOR DRILLING TOOL	FOR COLLET CHUCK	INSTALLATION DIRECTION
Thread 1/4-28 UNF-2B	Thread 9/32-40 UNS	bottom

Interface with the tool „Y“

MANUFACTURER	TYPE
Desoutter	Chapter 2.1 'Tools' on page 7

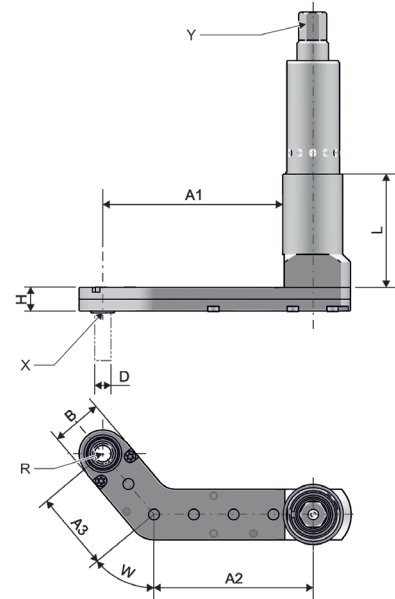

ITEM NO.	TYPE	MAX. Ø D [mm]	X	H [mm]	A1 [mm]	A2 [mm]	A3 [mm]	B [mm]	R [mm]	L [mm]	W [°]	WEIGHT [kg]
99260803	06-7,5-43,5	5,0	1/4-28 UNF-2B	7,5	57,1	50,4	25,2	16,0	7,5	36,0	50,0	0,196
99260806	06-08-48,5	5,0	1/4-28 UNF-2B	8,0	85,5	71,2	34,4	24,0	8,5	40,5	45,0	0,300
99260807	06-08-128	5,0	1/4-28 UNF-2B	8,0	85,5	71,2	34,4	24,0	8,5	120,0	45,0	0,425
99261003	06-10-50,5	6,35	1/4-28 UNF-2B	10,0	85,5	71,2	34,4	24,0	8,5	40,5	45,0	0,334
99261004	06-10-130	6,35	1/4-28 UNF-2B	10,0	85,5	71,2	34,4	24,0	8,5	120,0	45,0	0,459
99261304	06-12,5-53	8,0	1/4-28 UNF-2B	12,5	85,5	71,2	34,4	24,0	8,5	40,5	45,0	0,380
99261305	06-12,5-132,5	8,0	1/4-28 UNF-2B	12,5	85,5	71,2	34,4	24,0	8,5	120,0	45,0	0,505
99260813	06-7,5-43,5	5,0	9/32-40 UNS	7,5	57,1	50,4	25,2	16,0	7,5	36,0	50,0	0,196
99260814	06-08-48,5	5,0	9/32-40 UNS	8,0	85,5	71,2	34,4	24,0	8,5	40,5	45,0	0,299
99260815	06-08-128	5,0	9/32-40 UNS	8,0	85,5	71,2	34,4	24,0	8,5	120,0	45,0	0,425
99261009	06-10-50,5	6,35	9/32-40 UNS	10,0	85,5	71,2	34,4	24,0	8,5	40,5	45,0	0,334
99261010	06-10-130	6,35	9/32-40 UNS	10,0	85,5	71,2	34,4	24,0	8,5	120,0	45,0	0,459
99261310	06-12,5-53	8,0	9/32-40 UNS	12,5	85,5	71,2	34,4	24,0	8,5	40,5	45,0	0,380
99261311	06-12,5-132,5	8,0	9/32-40 UNS	12,5	85,5	71,2	34,4	24,0	8,5	120,0	45,0	0,505



2.7 L.DH1 SYSTEM 06-XX-XX – LEFT-ANGLED

Interface to drilling tool / collet chuck „X“

FOR DRILLING TOOL	FOR COLLET CHUCK	INSTALLATION DIRECTION
Thread 1/4-28 UNF-2B	Thread 9/32-40 UNS	bottom

Interface with the tool „Y“

MANUFACTURER	TYPE
Desoutter	Chapter 2.1 'Tools' on page 7

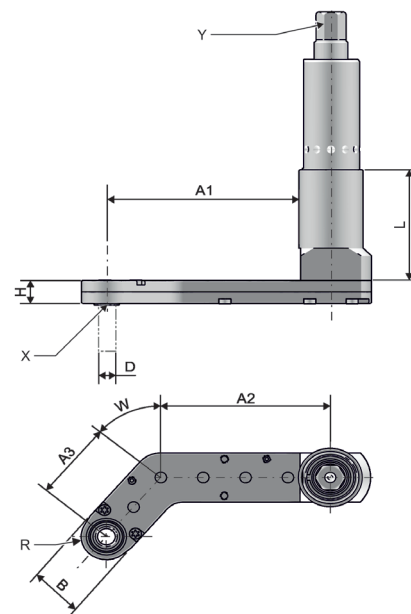

ITEM NO.	TYPE	MAX. Ø D [mm]	X	H [mm]	A1 [mm]	A2 [mm]	A3 [mm]	B [mm]	R [mm]	L [mm]	W [°]	WEIGHT [kg]
99260801	06-7,5-43,5	5,0	1/4-28 UNF-2B	7,5	57,1	50,4	25,2	16,0	7,5	36,0	50,0	0,196
99260808	06-08-48,5	5,0	1/4-28 UNF-2B	8,0	85,5	71,2	34,4	24,0	8,5	40,5	45,0	0,300
99260809	06-08-128	5,0	1/4-28 UNF-2B	8,0	85,5	71,2	34,4	24,0	8,5	120,0	45,0	0,425
99261006	06-10-50,5	6,35	1/4-28 UNF-2B	10,0	85,5	71,2	34,4	24,0	8,5	40,5	45,0	0,334
99261005	06-10-130	6,35	1/4-28 UNF-2B	10,0	85,5	71,2	34,4	24,0	8,5	120,0	45,0	0,459
99261306	06-12,5-53	8,0	1/4-28 UNF-2B	12,5	85,5	71,2	34,4	24,0	8,5	40,5	45,0	0,380
99261307	06-12,5-132,5	8,0	1/4-28 UNF-2B	12,5	85,5	71,2	34,4	24,0	8,5	120,0	45,0	0,505
99260816	06-7,5-43,5	5,0	9/32-40 UNS	7,5	57,1	50,4	25,2	16,0	7,5	36,0	50,0	0,196
99260817	06-08-48,5	5,0	9/32-40 UNS	8,0	85,5	71,2	34,4	24,0	8,5	40,5	45,0	0,299
99260818	06-08-128	5,0	9/32-40 UNS	8,0	85,5	71,2	34,4	24,0	8,5	120,0	45,0	0,424
99261012	06-10-50,5	6,35	9/32-40 UNS	10,0	85,5	71,2	34,4	24,0	8,5	40,5	45,0	0,333
99261013	06-10-130	6,35	9/32-40 UNS	10,0	85,5	71,2	34,4	24,0	8,5	120,0	45,0	0,459
99261312	06-12,5-53	8,0	9/32-40 UNS	12,5	85,5	71,2	34,4	24,0	8,5	40,5	45,0	0,380
99261313	06-12,5-132,5	8,0	9/32-40 UNS	12,5	85,5	71,2	34,4	24,0	8,5	120,0	45,0	0,505

3. ATLAS COPCO INTERFACE

3.1 TOOLS

TYPE	MODEL	MANUFACTURER NO.	ROTATIONAL SPEED [rpm]	OUTPUT [W]
PISTOL	LBP16M-005	8421012405	500	340
	LBP16M-010	8421012410	1000	340
	LBP16M-018	8421012418	1800	340
	LBP16M-033	8421012433	3300	340
	LBP16M-045	8421012445	4500	340
	LBP16M-060	8421012460	6000	340
STRAIGHT	LBD16M-005	8421012205	200 – 500	300
	LBD16M-010	8421012210	500 – 1000	300
	LBD16M-018	8421012218	800 – 1800	300
	LBD16M-032	8421012232	1500 – 3200	300
	LBD16M-045	8421012245	3200 – 4500	300
	LBD16M-055	8421012255	4500 – 5500	300

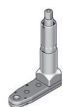

3.2 L.DH1 SYSTEM 03-XX-XX – STRAIGHT

Interface to drilling tool / collet chuck „X“

FOR DRILLING TOOL	FOR COLLET CHUCK	INSTALLATION DIRECTION
Thread 1/4-28 UNF-2B	Thread 9/32-40 UNS	top

Interface with the tool „Y“

MANUFACTURER	TYPE
Atlas Copco	Chapter 3.1 'Tools' on page 14

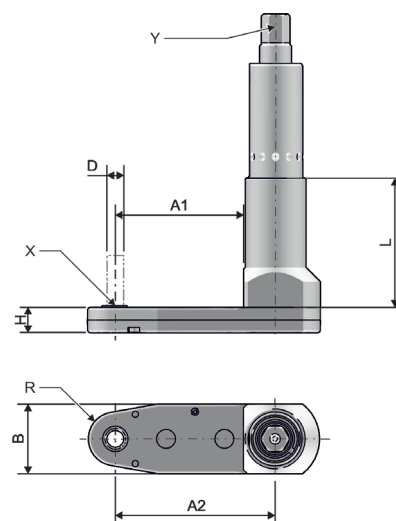

ITEM NO.	TYPE	MAX. Ø D [mm]	X	H [mm]	A1 [mm]	A2 [mm]	B [mm]	R [mm]	L [mm]	WEIGHT [kg]
99230805	03-08-48,5	5,0	1/4-28 UNF-2B	8,0	40,4	50,4	24,0	8,5	40,5	0,221
99230806	03-08-128	5,0	1/4-28 UNF-2B	8,0	40,4	50,4	24,0	8,5	120,0	0,346
99231002	03-10-50,5	6,35	1/4-28 UNF-2B	10,0	40,4	50,4	24,0	8,5	40,5	0,239
99231007	03-10-130	6,35	1/4-28 UNF-2B	10,0	40,4	50,4	24,0	8,5	120,0	0,364
99231305	03-12,5-53	8,0	1/4-28 UNF-2B	12,5	40,4	50,4	24,0	8,5	40,5	0,266
99231306	03-12,5-132,5	8,0	1/4-28 UNF-2B	12,5	40,4	50,4	24,0	8,5	120,0	0,391
99230807	03-08-48,5	5,0	9/32-40 UNS	8,0	40,4	50,4	24,0	8,5	40,5	0,221
99230808	03-08-128	5,0	9/32-40 UNS	8,0	40,4	50,4	24,0	8,5	120,0	0,346
99231008	03-10-50,5	6,35	9/32-40 UNS	10,0	40,4	50,4	24,0	8,5	40,5	0,239
99231009	03-10-130	6,35	9/32-40 UNS	10,0	40,4	50,4	24,0	8,5	120,0	0,364
99231302	03-12,5-53	8,0	9/32-40 UNS	12,5	40,4	50,4	24,0	8,5	40,5	0,265
99231307	03-12,5-132,5	8,0	9/32-40 UNS	12,5	40,4	50,4	24,0	8,5	120,0	0,390



3.3 L.DH1 SYSTEM 04-XX-XX – STRAIGHT

Interface to drilling tool / collet chuck „X“

FOR DRILLING TOOL	FOR COLLET CHUCK	INSTALLATION DIRECTION
Thread 1/4-28 UNF-2B	Thread 9/32-40 UNS	bottom

Interface with the tool „Y“

MANUFACTURER	TYPE
Atlas Copco	Chapter 3.1 'Tools' on page 14

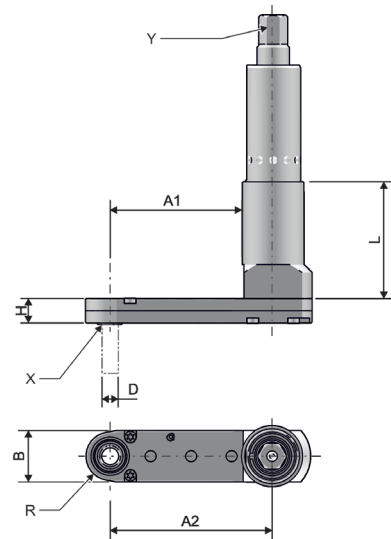

ITEM NO.	TYPE	MAX. Ø D [mm]	X	H [mm]	A1 [mm]	A2 [mm]	B [mm]	R [mm]	L [mm]	WEIGHT [kg]
99240807	04-7,5-43,5	5,0	1/4-28 UNF-2B	7,5	40,9	50,4	16,0	7,5	36,0	0,173
99240808	04-08-48,5	5,0	1/4-28 UNF-2B	8,0	58,8	68,8	24,0	8,5	40,5	0,247
99240809	04-08-128	5,0	1/4-28 UNF-2B	8,0	58,8	68,8	24,0	8,5	120,0	0,372
99241005	04-10-50,5	6,35	1/4-28 UNF-2B	10,0	58,8	68,8	24,0	8,5	40,5	0,271
99241006	04-10-130	6,35	1/4-28 UNF-2B	10,0	58,8	68,8	24,0	8,5	120,0	0,396
99241306	04-12,5-53	8,0	1/4-28 UNF-2B	12,5	58,8	68,8	24,0	8,5	40,5	0,303
99241307	04-12,5-132,5	8,0	1/4-28 UNF-2B	12,5	58,8	68,8	24,0	8,5	120,0	0,428
99240810	04-7,5-43,5	5,0	9/32-40 UNS	7,5	40,9	50,4	16,0	7,5	36,0	0,173
99240811	04-08-48,5	5,0	9/32-40 UNS	8,0	58,8	68,8	24,0	8,5	40,5	0,247
99240812	04-08-128	5,0	9/32-40 UNS	8,0	58,8	68,8	24,0	8,5	120,0	0,372
99241007	04-10-50,5	6,35	9/32-40 UNS	10,0	58,8	68,8	24,0	8,5	40,5	0,270
99241008	04-10-130	6,35	9/32-40 UNS	10,0	58,8	68,8	24,0	8,5	120,0	0,395
99241308	04-12,5-53	8,0	9/32-40 UNS	12,5	58,8	68,8	24,0	8,5	40,5	0,303
99241309	04-12,5-132,5	8,0	9/32-40 UNS	12,5	58,8	68,8	24,0	8,5	120,0	0,428

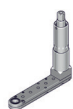

3.4 L.DH1 SYSTEM 06-XX-XX – STRAIGHT

Interface to drilling tool / collet chuck „X“

FOR DRILLING TOOL	FOR COLLET CHUCK	INSTALLATION DIRECTION
Thread 1/4-28 UNF-2B	Thread 9/32-40 UNS	bottom

Interface with the tool „Y“

MANUFACTURER	TYPE
Atlas Copco	Chapter 3.1 'Tools' on page 14

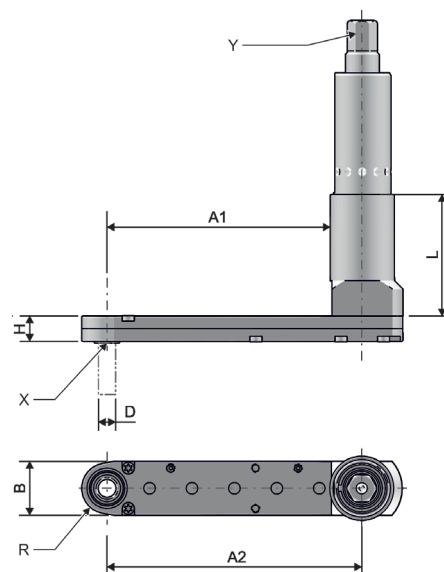

ITEM NO.	TYPE	MAX. Ø D [mm]	X	H [mm]	A1 [mm]	A2 [mm]	B [mm]	R [mm]	L [mm]	WEIGHT [kg]
99260819	06-7,5-43,5	5,0	1/4-28 UNF-2B	7,5	66,1	75,6	16,0	7,5	36,0	0,195
99260820	06-08-48,5	5,0	1/4-28 UNF-2B	8,0	95,6	105,6	24,0	8,5	40,5	0,299
99260821	06-08-128	5,0	1/4-28 UNF-2B	8,0	95,6	105,6	24,0	8,5	120,0	0,424
99261014	06-10-50,5	6,35	1/4-28 UNF-2B	10,0	95,6	105,6	24,0	8,5	40,5	0,333
99261015	06-10-130	6,35	1/4-28 UNF-2B	10,0	95,6	105,6	24,0	8,5	120,0	0,458
99261314	06-12,5-53	8,0	1/4-28 UNF-2B	12,5	95,6	105,6	24,0	8,5	40,5	0,379
99261315	06-12,5-132,5	8,0	1/4-28 UNF-2B	12,5	95,6	105,6	24,0	8,5	120,0	0,504
99260828	06-7,5-43,5	5,0	9/32-40 UNS	7,5	66,1	75,6	16,0	7,5	36,0	0,195
99260829	06-08-48,5	5,0	9/32-40 UNS	8,0	95,6	105,6	24,0	8,5	40,5	0,298
99260830	06-08-128	5,0	9/32-40 UNS	8,0	95,6	105,6	24,0	8,5	120,0	0,423
99261020	06-10-50,5	6,35	9/32-40 UNS	10,0	95,6	105,6	24,0	8,5	40,5	0,333
99261021	06-10-130	6,35	9/32-40 UNS	10,0	95,6	105,6	24,0	8,5	120,0	0,458
99261320	06-12,5-53	8,0	9/32-40 UNS	12,5	95,6	105,6	24,0	8,5	40,5	0,379
99261321	06-12,5-132,5	8,0	9/32-40 UNS	12,5	95,6	105,6	24,0	8,5	120,0	0,504



3.5 L.DH1 SYSTEM 08-XX-XX – STRAIGHT

Interface to drilling tool / collet chuck „X“

FOR DRILLING TOOL	FOR COLLET CHUCK	INSTALLATION DIRECTION
Thread 1/4-28 UNF-2B	Thread 9/32-40 UNS	bottom

Interface with the tool „Y“

MANUFACTURER	TYPE
Atlas Copco	Chapter 3.1 'Tools' on page 14

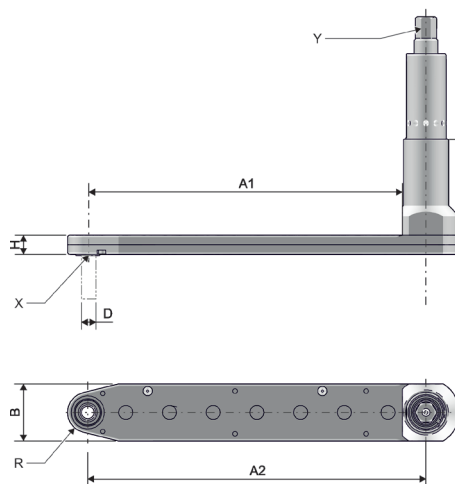

ITEM NO.	TYPE	MAX. Ø D [mm]	X	H [mm]	A1 [mm]	A2 [mm]	B [mm]	R [mm]	L [mm]	WEIGHT [kg]
99280806	08-7,5-43,5	5,0	1/4-28 UNF-2B	7,5	91,3	100,8	16,0	7,5	36,0	0,218
99280807	08-08-48,5	5,0	1/4-28 UNF-2B	8,0	132,4	142,4	24,0	8,5	40,5	0,351
99280808	08-08-128	5,0	1/4-28 UNF-2B	8,0	132,4	142,4	24,0	8,5	120,0	0,476
99281005	08-10-50,5	6,35	1/4-28 UNF-2B	10,0	132,4	142,4	24,0	8,5	40,5	0,396
99281006	08-10-130	6,35	1/4-28 UNF-2B	10,0	132,4	142,4	24,0	8,5	120,0	0,521
99281305	08-12,5-53	8,0	1/4-28 UNF-2B	12,5	132,4	142,4	24,0	8,5	40,5	0,456
99281306	08-12,5-132,5	8,0	1/4-28 UNF-2B	12,5	132,4	142,4	24,0	8,5	120,0	0,581
99280809	08-7,5-43,5	5,0	9/32-40 UNS	7,5	91,3	100,8	16,0	7,5	36,0	0,217
99280810	08-08-48,5	5,0	9/32-40 UNS	8,0	132,4	142,4	24,0	8,5	40,5	0,351
99280811	08-08-128	5,0	9/32-40 UNS	8,0	132,4	142,4	24,0	8,5	120,0	0,476
99281002	08-10-50,5	6,35	9/32-40 UNS	10,0	132,4	142,4	24,0	8,5	40,5	0,396
99281007	08-10-130	6,35	9/32-40 UNS	10,0	132,4	142,4	24,0	8,5	120,0	0,521
99281307	08-12,5-53	8,0	9/32-40 UNS	12,5	132,4	142,4	24,0	8,5	40,5	0,456
99281308	08-12,5-132,5	8,0	9/32-40 UNS	12,5	132,4	142,4	24,0	8,5	120,0	0,581



3.6 L.DH1 SYSTEM 06-XX-XX – RIGHT-ANGLED

Interface to drilling tool / collet chuck „X“

FOR DRILLING TOOL	FOR COLLET CHUCK	INSTALLATION DIRECTION
Thread 1/4-28 UNF-2B	Thread 9/32-40 UNS	bottom

Interface with the tool „Y“

MANUFACTURER	TYPE
Atlas Copco	Chapter 3.1 'Tools' on page 14

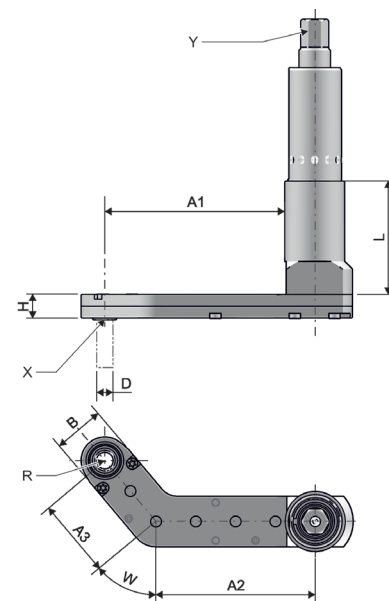

ITEM NO.	TYPE	MAX. Ø D [mm]	X	H [mm]	A1 [mm]	A2 [mm]	A3 [mm]	B [mm]	R [mm]	L [mm]	W [°]	WEIGHT [kg]
99260822	06-7,5-43,5	5,0	1/4-28 UNF-2B	7,5	57,1	50,4	25,2	16,0	7,5	36,0	50,0	0,195
99260823	06-08-48,5	5,0	1/4-28 UNF-2B	8,0	85,5	71,2	34,4	24,0	8,5	40,5	45,0	0,299
99260824	06-08-128	5,0	1/4-28 UNF-2B	8,0	85,5	71,2	34,4	24,0	8,5	120,0	45,0	0,424
99261016	06-10-50,5	6,35	1/4-28 UNF-2B	10,0	85,5	71,2	34,4	24,0	8,5	40,5	45,0	0,333
99261017	06-10-130	6,35	1/4-28 UNF-2B	10,0	85,5	71,2	34,4	24,0	8,5	120,0	45,0	0,458
99261316	06-12,5-53	8,0	1/4-28 UNF-2B	12,5	85,5	71,2	34,4	24,0	8,5	40,5	45,0	0,379
99261317	06-12,5-132,5	8,0	1/4-28 UNF-2B	12,5	85,5	71,2	34,4	24,0	8,5	120,0	45,0	0,504
99260831	06-7,5-43,5	5,0	9/32-40 UNS	7,5	57,1	50,4	25,2	16,0	7,5	36,0	50,0	0,195
99260832	06-08-48,5	5,0	9/32-40 UNS	8,0	85,5	71,2	34,4	24,0	8,5	40,5	45,0	0,298
99260833	06-08-128	5,0	9/32-40 UNS	8,0	85,5	71,2	34,4	24,0	8,5	120,0	45,0	0,423
99261022	06-10-50,5	6,35	9/32-40 UNS	10,0	85,5	71,2	34,4	24,0	8,5	40,5	45,0	0,333
99261023	06-10-130	6,35	9/32-40 UNS	10,0	85,5	71,2	34,4	24,0	8,5	120,0	45,0	0,458
99261325	06-12,5-53	8,0	9/32-40 UNS	12,5	85,5	71,2	34,4	24,0	8,5	40,5	45,0	0,379
99261322	06-12,5-132,5	8,0	9/32-40 UNS	12,5	85,5	71,2	34,4	24,0	8,5	120,0	45,0	0,504



3.7 L.DH1 SYSTEM 06-XX-XX – LEFT-ANGLED

Interface to drilling tool / collet chuck „X“

FOR DRILLING TOOL	FOR COLLET CHUCK	INSTALLATION DIRECTION
Thread 1/4-28 UNF-2B	Thread 9/32-40 UNS	bottom

Interface with the tool „Y“

MANUFACTURER	TYPE
Atlas Copco	Chapter 3.1 'Tools' on page 14

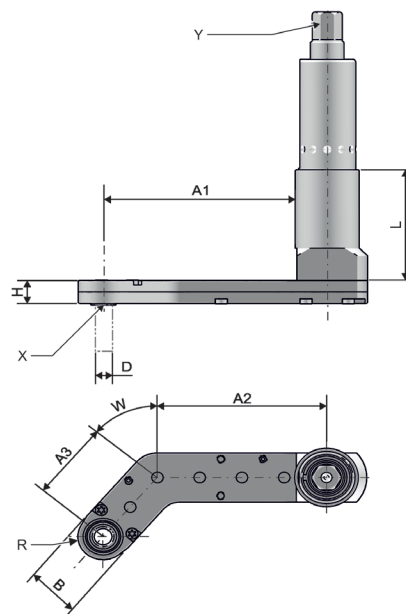

ITEM NO.	TYPE	MAX. Ø D [mm]	X	H [mm]	A1 [mm]	A2 [mm]	A3 [mm]	B [mm]	R [mm]	L [mm]	W [°]	WEIGHT [kg]
99260825	06-7,5-43,5	5,0	1/4-28 UNF-2B	7,5	57,1	50,4	25,2	16,0	7,5	36,0	50,0	0,195
99260826	06-08-48,5	5,0	1/4-28 UNF-2B	8,0	85,5	71,2	34,4	24,0	8,5	40,5	45,0	0,299
99260827	06-08-128	5,0	1/4-28 UNF-2B	8,0	85,5	71,2	34,4	24,0	8,5	120,0	45,0	0,424
99261018	06-10-50,5	6,35	1/4-28 UNF-2B	10,0	85,5	71,2	34,4	24,0	8,5	40,5	45,0	0,333
99261019	06-10-130	6,35	1/4-28 UNF-2B	10,0	85,5	71,2	34,4	24,0	8,5	120,0	45,0	0,458
99261318	06-12,5-53	8,0	1/4-28 UNF-2B	12,5	85,5	71,2	34,4	24,0	8,5	40,5	45,0	0,379
99261319	06-12,5-132,5	8,0	1/4-28 UNF-2B	12,5	85,5	71,2	34,4	24,0	8,5	120,0	45,0	0,504
99260834	06-7,5-43,5	5,0	9/32-40 UNS	7,5	57,1	50,4	25,2	16,0	7,5	36,0	50,0	0,195
99260835	06-08-48,5	5,0	9/32-40 UNS	8,0	85,5	71,2	34,4	24,0	8,5	40,5	45,0	0,298
99260836	06-08-128	5,0	9/32-40 UNS	8,0	85,5	71,2	34,4	24,0	8,5	120,0	45,0	0,423
99261024	06-10-50,5	6,35	9/32-40 UNS	10,0	85,5	71,2	34,4	24,0	8,5	40,5	45,0	0,333
99261025	06-10-130	6,35	9/32-40 UNS	10,0	85,5	71,2	34,4	24,0	8,5	120,0	45,0	0,458
99261323	06-12,5-53	8,0	9/32-40 UNS	12,5	85,5	71,2	34,4	24,0	8,5	40,5	45,0	0,379
99261324	06-12,5-132,5	8,0	9/32-40 UNS	12,5	85,5	71,2	34,4	24,0	8,5	120,0	45,0	0,504